

Nominal data

Type	8314 G	
Nominal voltage	VDC	24
Nominal voltage range	VDC	12 .. 28
Speed	min ⁻¹	3300
Power input	W	2.5
Min. ambient temperature	°C	-20
Max. ambient temperature	°C	75
Air flow	m ³ /h	54
Sound power level	B	5.2
Sound pressure level	dB(A)	36

ml = Max. load · me = Max. efficiency · fa = Running at free air · cs = Customer specs · cu = Customer unit
Subject to alterations

8314 G

DC axial compact fan

Technical features

Mass	0.170 kg
Dimensions	80 x 80 x 32 mm
Material of impeller	Fiberglass-reinforced PA plastic
Housing material	Fiberglass-reinforced PBT plastic
Direction of air flow	Air exhaust over bars
Direction of rotation	Right, looking at rotor
Bearing	Sintec sleeve bearing
Lifetime L10 at 40 °C	70000 h
Lifetime L10 at maximum temperature	30000 h
Connection line	Single strands AWG 22, TR 64, bared and tin-plated.
Motor protection	Protected against reverse polarity and locking.
Locked-rotor protection	Blocking and overload protection
Approval	VDE, CSA, UL, CE

8314 G

DC axial compact fan

Product drawing

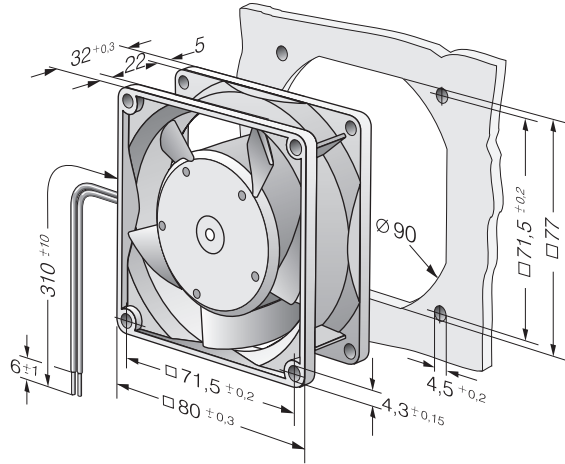

Charts: Air flow

